

# BLAGDON

## B25 & X25

AIR OPERATED DOUBLE DIAPHRAGM PUMP

Metallic FDA '05' Series

### B25

### DIMENSIONS

General Assembly :- B2505 Metallic FDA Pump  
All dimensions +/- 3mm

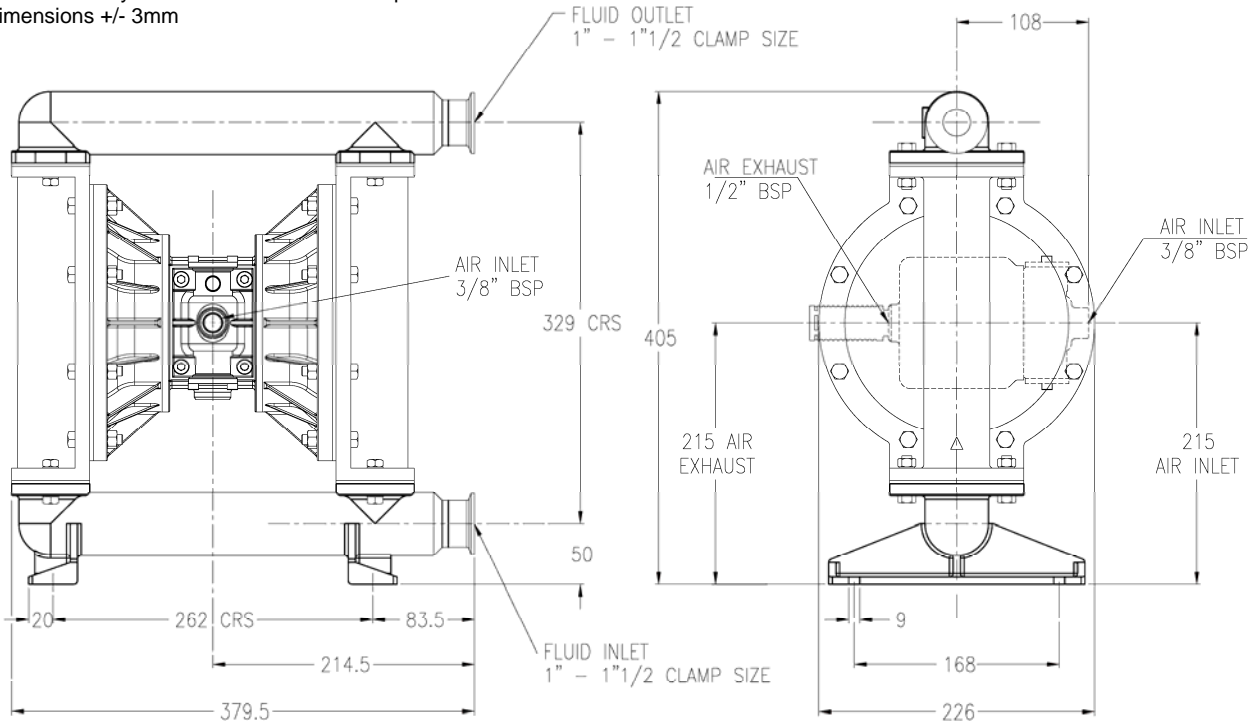

### B25

### PERFORMANCE

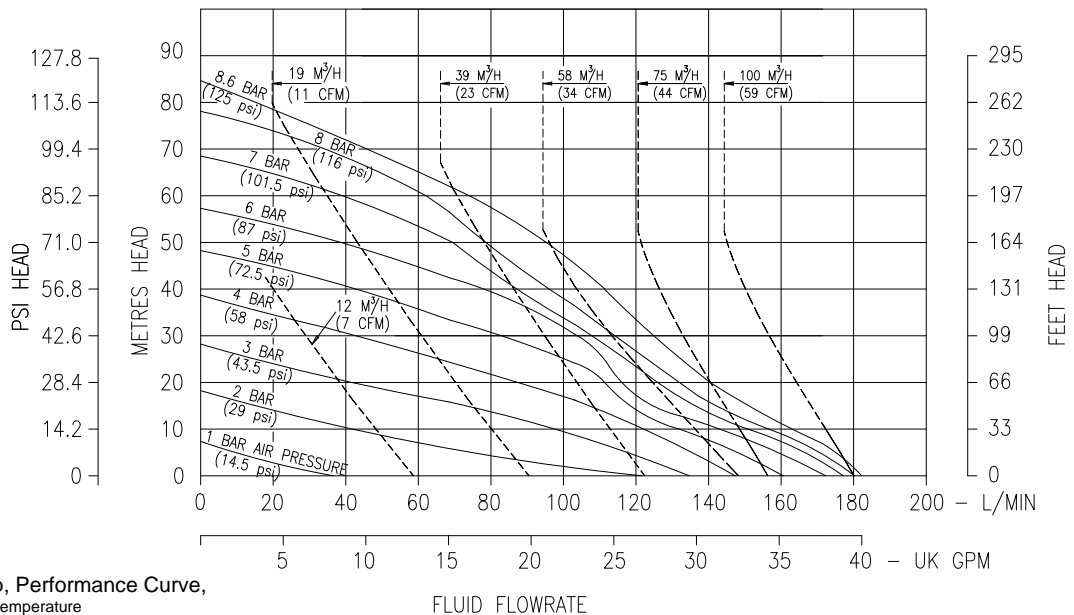

B2505 Metallic Pump, Performance Curve,  
based on water at ambient temperature

<b>FLUID CONNECTIONS</b> 1" - 1 1/2" TRI-CLAMP SIZE Other options available (RJT/DIN)	<b>CAPACITY</b> 0 - 180 Litres/Minute (0 - 40 Gallons/Minute)	<b>MAX SOLIDS</b> 3 MM (1/8")	<b>MAX DISCHARGE HEAD</b> 88 Meters (289 ft)	<b>DISPLACEMENT/STROKE</b> 0.475 Litres (0.1 UK Gallons)
<b>MAX. WORKING PRESSURE</b> 8.6 Bar (125 psi)	<b>AIR INLET</b> 3/8" BSP (F)	<b>TEMPERATURE LIMITS</b> Determined by Elastomers		<b>PUMP WEIGHTS :-</b> SA :- 22.5 Kg    SS : 32.5 Kg

**ⓘ Caution - Operating temperature limitations are as follows:**

Operating Temperatures

Materials	Maximum	Minimum	Optimum
<b>Buna-n</b> - General purpose, oil resistant. Shows good solvent, oil, water and hydraulic fluid resistance. Should not be used with highly polar solvents like acetone and MEK, ozone, chlorinated hydrocarbons and nitro hydrocarbons.	176°F 80°C	-18°F -28°C	50° to 140°F 10° to 60°C
<b>EPDM</b> - Shows very good water and chemical resistance. Has poor resistance to oils and solvents, but is fair on ketones and alcohols.	212°F 100°C	-11°F -24°C	50° to 212°F 10° to 100°C
<b>Neoprene</b> - All purpose. Resistant to vegetable oil. Generally not affected by moderate chemicals, fats greases and many oils and solvents. Generally attacked by strong oxidising acids, ketones, esters, nitro hydro carbons and chlorinated aromatic hydrocarbons.	212°F 100°C	-4°F -20°C	50° to 130°F 10° to 54°C
<b>Santoprene®</b> - Injection moulded thermoplastic elastomer with no fabric layer. Long mechanical flex life. Excellent abrasion resistance.	212°F 100°C	-10°F -23°C	50° to 212°F 10° to 100°C
<b>PTFE</b> - Chemically inert, virtually impervious. Very few chemicals are known to react chemically with PTFE : molten alkali metals, turbulent liquid or gaseous fluorine and a few fluoro-chemicals such as chlorine trifluoride or oxygen difluoride which readily liberate free fluorine at elevated temperatures.	356°F 180°C	32°F 0°C	50° to 212°F 10° to 100°C
<b>Viton®</b> - Shows good resistance to a wide range of oils and solvents : especially all aliphatic, aromatic and halogenated hydrocarbons, acids, animal and vegetable oils.	356°F 180°C	0°F -18°C	75° to 212°F 24° to 100°C

**TYPICAL CODE = B25.05.S A. B B. E T S - P**

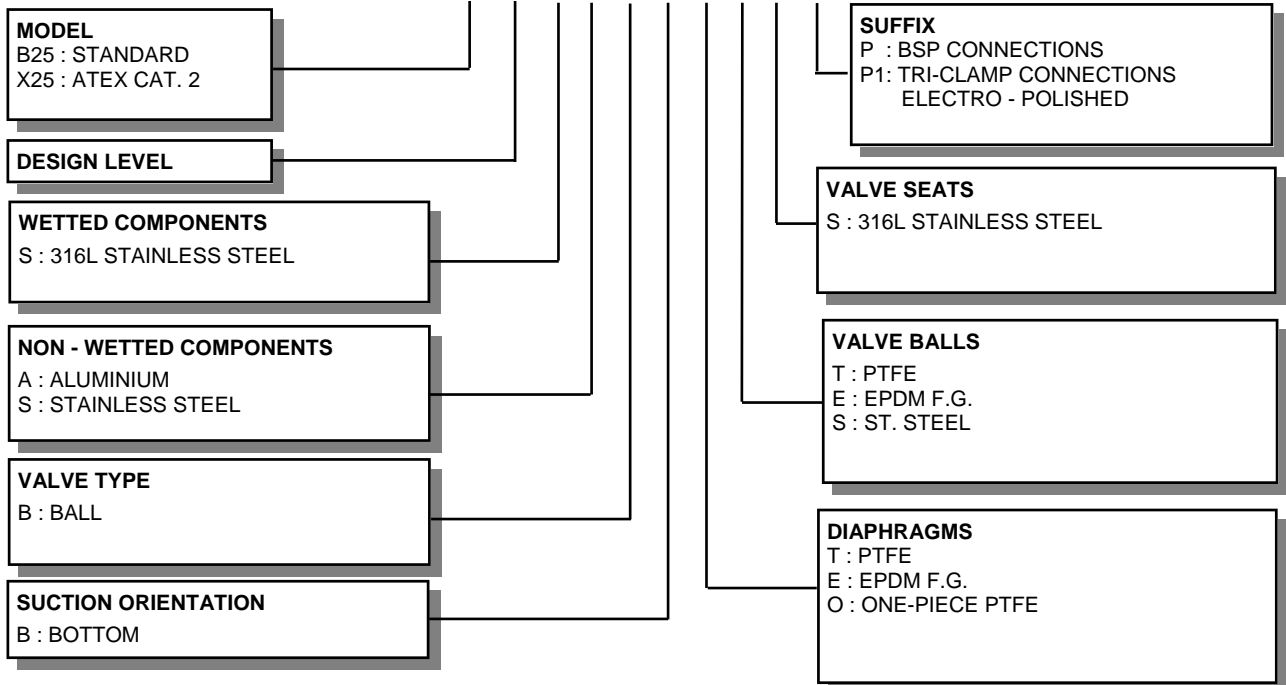

**IMPORTANT**

This pump should be used in accordance with the requirements of the Health and Safety at Work Act 1974. All business conducted subject to Blagdon Pump. Terms and Conditions of Sale, available on request.



LAMBERT ROAD, ARMSTRONG, WASHINGTON,  
TYNE & WEAR NE37 1QP ENGLAND.  
TEL : 0044 (0) 191 4177475  
FAX : 0044 (0) 191 4175435  
Web Site : www.blagdonpump.com  
E-Mail : sales@blagdonpump.com