



# BLAGDON

## B50 & X50

AIR OPERATED DOUBLE DIAPHRAGM PUMP

2" Hygienic Series

**B50**

**DIMENSIONS**

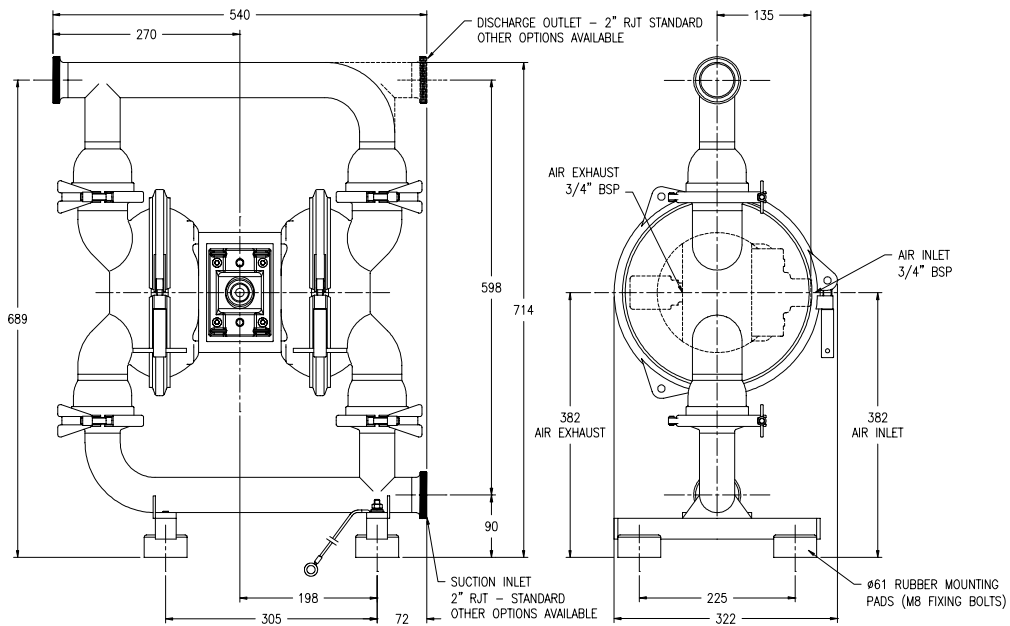

General Assembly :-  
B50 Hygienic Pump  
All dimensions +/- 3mm

**B50**

**PERFORMANCE**

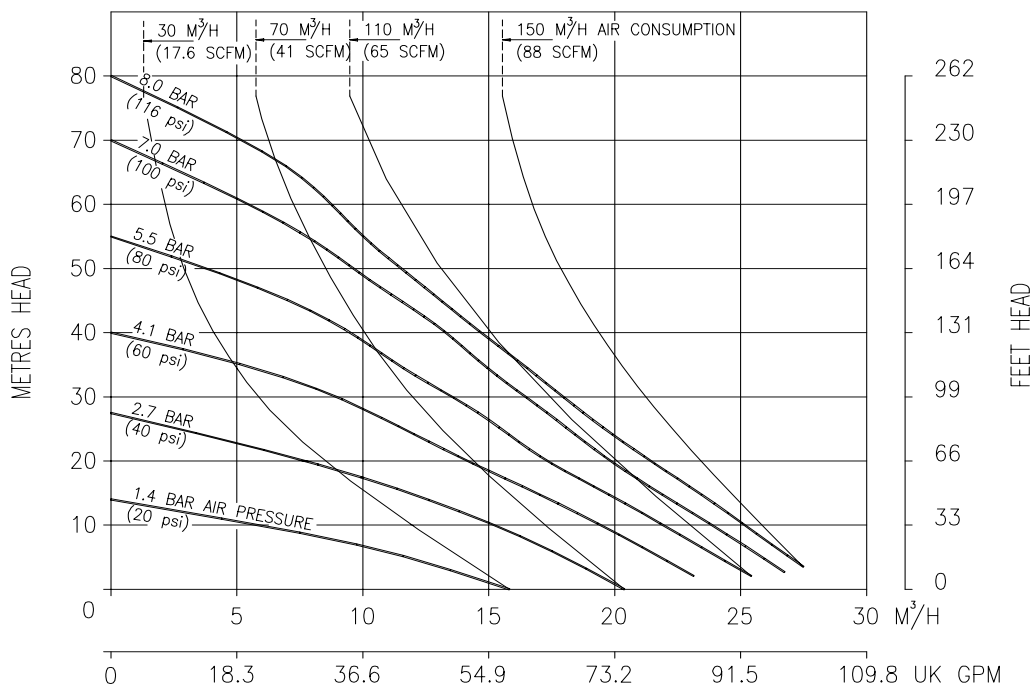

B50 Hygienic Pump Performance Curve  
Performance based on water at ambient temperature  
HG-CF-1064 Rev. A - 25.05.03

FLUID FLOWRATE

<b>FLUID CONNECTIONS</b> 2" RJT Male	<b>CAPACITY</b> 0 - 476 Litres/Minute (0 - 105 Gallons/Minute)	<b>MAX SOLIDS</b> 10 MM (3/8")	<b>MAX DISCHARGE HEAD</b> 88 Meters (289 ft)	<b>DISPLACEMENT/STROKE</b> 1.9 Litres (0.42 UK Gallons)
<b>MAX. WORKING PRESSURE</b> 8.6 Bar (125 psi)	<b>AIR INLET</b> 3/4" BSP (F)	<b>TEMPERATURE LIMITS</b> Determined by Elastomers		<b>PUMP WEIGHTS :-</b> ZF :- 42 Kg ZS :- 64 Kg

**ⓘ Caution - Operating temperature limitations are as follows:**

**Operating Temperatures**

Materials	Maximum	Minimum	Optimum
<b>EPDM</b> - Shows very good water and chemical resistance. Has poor resistance to oils and solvents, but is fair on ketones and alcohols.	212°F 100°C	-10°F -23°C	50° to 212°F 10° to 100°C
<b>PTFE</b> - Chemically inert, virtually impervious. Very few chemicals are known to react chemically with PTFE : molten alkali metals, turbulent liquid or gaseous fluorine and a few fluoro-chemicals such as chlorine trifluoride or oxygen difluoride which readily liberate free fluorine at elevated temperatures.	212°F 100°C	-35°F -37°C	50° to 212°F 10° to 100°C

- Gentle pumping action to avoid damage to food and beverage products.
- Range of RJT / DIN / FERRULE connections.
- Self priming for emptying containers.
- Lube-Free as standard.
- Food grade elastomers – EPDM / PTFE
- Pressures to 8.6 bar.
- Capable of handling high viscosity & SG fluids.
- Certified CIP cleanable.
- EU Design approval
- 316L Stainless steel
- Pump Stand option for 180° rotation in place.

**TYPICAL CODE = B50.02.Z F. B B. E E E**

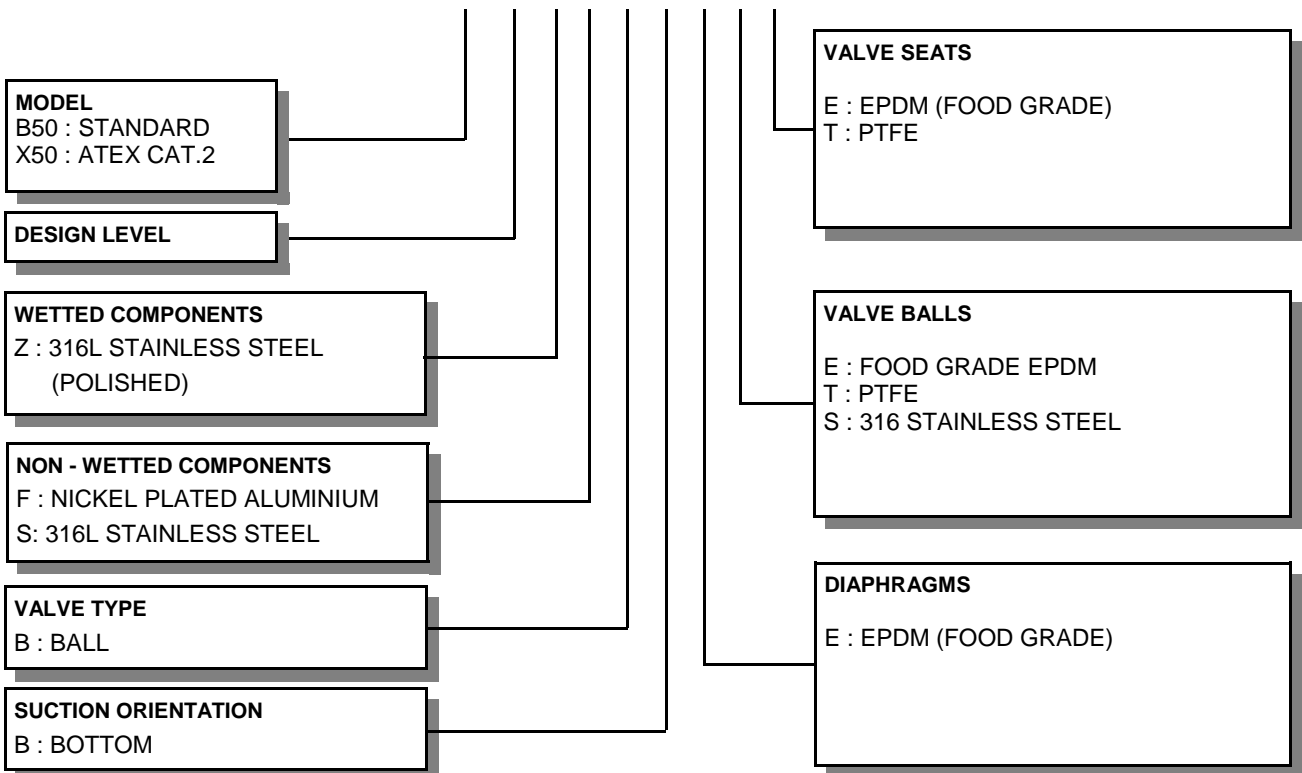

**IMPORTANT**

This pump should be used in accordance with the requirements of the Health and Safety at Work Act 1974. All business conducted subject to Blagdon Pump. Terms and Conditions of Sale, available on request.



LAMBERT ROAD, ARMSTRONG, WASHINGTON,  
TYNE & WEAR NE37 1QP ENGLAND.  
TEL. : 0044 (0) 191 4177475  
FAX. : 0044 (0) 191 4175435  
Web Site : www.blagdonpump.com  
E-Mail : sales@blagdonpump.com