

# SERVICE & OPERATING MANUAL AIR OPERATED DOUBLE DIAPHRAGM PUMP

## B50 & X50

### 50 Series 2" Model

This pump is ATEX approved for use  
in potentially explosive atmospheres  
Group II category 2



#### This Manual covers the following models :-

5004AA....	All Aluminium
5004CA....	Cast Iron / Aluminium
5004CC....	All Cast Iron
5004SA....	Stainless Steel / Aluminium
5004SC....	Stainless Steel / Cast Iron
5004SS....	All Stainless Steel

All Standard & Lube Free models, BSP & NPT  
Flanged models :- ANSI 150, PN16 etc.  
Private labelled models.  
Atex Certified models.

**NOTE!** Refer to pump Typical Code matrix on page 3 to determine the full Model No. of your pump.

Please read all warnings and instructions before using this product.

#### **IMPORTANT**

This pump should be used in accordance with the requirements of the Health and Safety at Work Act 1974.  
All business conducted subject to Blagdon Pump. Terms and Conditions of Sale, available on request.

A Unit of IDEX Corporation



# Table of Contents

Contact Information .....	2
Temperature Limitations.....	3
Explanation of Pump Nomenclature .....	3
Dimensional Drawings .....	4
Performance Curve .....	5
Trouble Shooting .....	6
Technical Data .....	6
Principle of Pump Operation .....	7
Installation guide .....	7
Important warnings and Safety Information .....	8
Exhaust Safety Instructions .....	9
Atex models, Grounding the pump .....	9
Warranty .....	10
Service .....	10
Air Valve Overhaul .....	10
Wet-side Overhaul .....	10
B5004CC, PTFE Diaphragms, Torque Settings .....	11
Elastomer Table .....	11
Sectional Drawings .....	12
Parts List - Wet Side .....	13
High Temperature Specification .....	13
Parts List - Air Side .....	14
Atex Certified models .....	15
Flanges (ANSI 150, PN16 etc.) & Base Pads .....	15
Wet Side Kit structure & Spares Kits .....	16
Service / Maintenance Log .....	17
Recycling .....	17
Declaration of Conformity .....	18

Contact Information	
Contact	Phone / E-Mail / Fax No.



LAMBERT ROAD, ARMSTRONG, WASHINGTON,  
 TYNE & WEAR NE37 1QP, ENGLAND.  
 TEL. : 0044 (0) 191 4177475  
 FAX. : 0044 (0) 191 4175435  
 Web Site : [www.blagdonpump.com](http://www.blagdonpump.com)  
 E-Mail : [sales@blagdonpump.com](mailto:sales@blagdonpump.com)

## Temperature Guide & Pump Code Matrix

**ⓘ Caution - Operating temperature limitations are as follows:**

Operating Temperatures

Materials	Maximum	Minimum	Optimum
<b>Buna-n</b> - General purpose, oil resistant. Shows good solvent, oil, water and hydraulic fluid resistance. Should not be used with highly polar solvents like acetone and MEK, ozone, chlorinated hydrocarbons and nitro hydrocarbons.	176°F 80°C	-18°F -28°C	50° to 140°F 10° to 60°C
<b>EPDM</b> - Shows very good water and chemical resistance. Has poor resistance to oils and solvents, but is fair on ketones and alcohols.	212°F 100°C	-11°F -24°C	50° to 212°F 10° to 100°C
<b>Neoprene</b> - All purpose. Resistant to vegetable oil. Generally not affected by moderate chemicals, fats greases and many oils and solvents. Generally attacked by strong oxidising acids, ketones, esters, nitro hydro carbons and chlorinated aromatic hydrocarbons.	212°F 100°C	-4°F -20°C	50° to 130°F 10° to 54°C
<b>Santoprene®</b> - Injection moulded thermoplastic elastomer with no fabric layer. Long mechanical flex life. Excellent abrasion resistance.	212°F 100°C	-10°F -23°C	50° to 212°F 10° to 100°C
<b>PTFE</b> - Chemically inert, virtually impervious. Very few chemicals are known to react chemically with PTFE : molten alkali metals, turbulent liquid or gaseous fluorine and a few fluoro-chemicals such as chlorine trifluoride or oxygen difluoride which readily liberate free fluorine at elevated temperatures.	356°F 180°C	32°F 0°C	50° to 212°F 10° to 100°C
<b>Viton®</b> - Shows good resistance to a wide range of oils and solvents : especially all aliphatic, aromatic and halogenated hydrocarbons, acids, animal and vegetable oils.	356°F 180°C	0°F -18°C	75° to 212°F 24° to 100°C
<b>Polypropylene</b> - High strength, light weight, corrosion resistant polyolefin which easily withstands most chemicals, with no known solvent at room temperature.	158°F 70°C	32°F 0°C	50° to 140°F 10° to 60°C

**TYPICAL CODE = B 50.04. A A. B B. N N S - LF**

**PREFIX**

B : BLAGDON UK  
N : BLAGDON USA  
V : VERSA-MATIC  
X : ATEX CERTIFIED

**MODEL NO.**

50 : 2"

**DESIGN LEVEL**

**WETTED COMPONENTS**

A : ALUMINIUM  
C : CAST IRON  
S : 316L STAINLESS STEEL

**NON - WETTED COMPONENTS**

A : ALUMINIUM  
C : CAST IRON  
S : 304 STAINLESS STEEL

**VALVE TYPE**

B : BALL  
W : WEIGHTED BALL

**SUCTION ORIENTATION**

B : BOTTOM

**SUFFIX - (WHERE APPLICABLE)**

LF : LUBE FREE  
F : FLANGED - ANSI 150  
N : NPT THREADS  
H : HYDROSTATIC TEST  
(A THREE DIGIT NUMBER SUFFIX DENOTES A SPECIAL DESIGN  
i.e. 301 = OPPOSED SUCTION)

**VALVE SEATS**

B : BUNA-N                      S : ST. STEEL  
E : EPDM                        A : ALUMINIUM  
N : NEOPRENE                V : VITON  
T : PTFE

**VALVE BALLS**

B : BUNA-N                      T : PTFE  
E : EPDM                        V : VITON  
N : NEOPRENE                S : ST. STEEL  
D : DELRIN (ACETAL)

**DIAPHRAGMS**

B : BUNA-N                      T : PTFE  
E : EPDM                        V : VITON  
H : POLYESTER (HYTREL)  
N : NEOPRENE  
P : POLYURETHANE   
R : SANTOPRENE  
O : ONE-PIECE PTFE  
X : PTFE/VITON (HIGH TEMP.)  
(SEE PAGE 12 FOR DETAILS ON SPECIFYING  
HIGH TEMPERATURE APPLICATIONS)

**Exclusions :**

- = Not available with 'X' prefix pumps.
- = Only available on Stainless Steel wetted models.

# GA Drawings

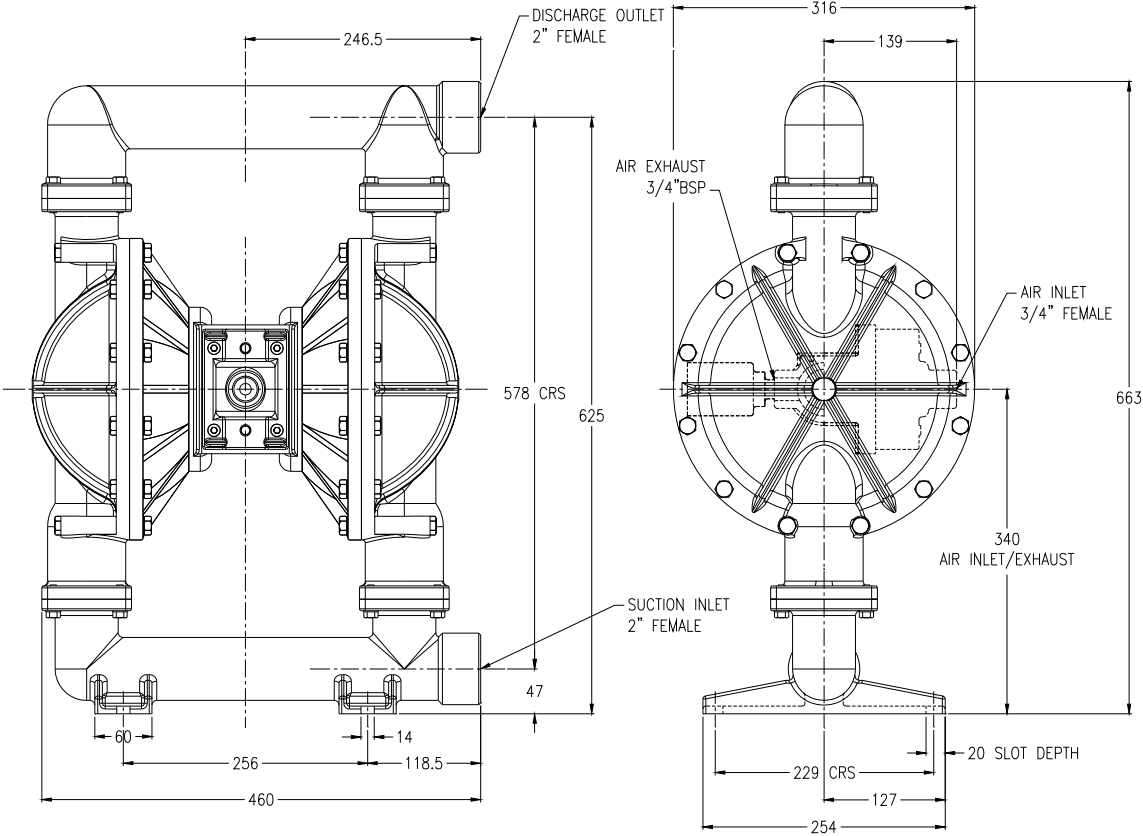

**General Assembly :- B5004 Aluminium Pump, all dimensions +/- 2mm**

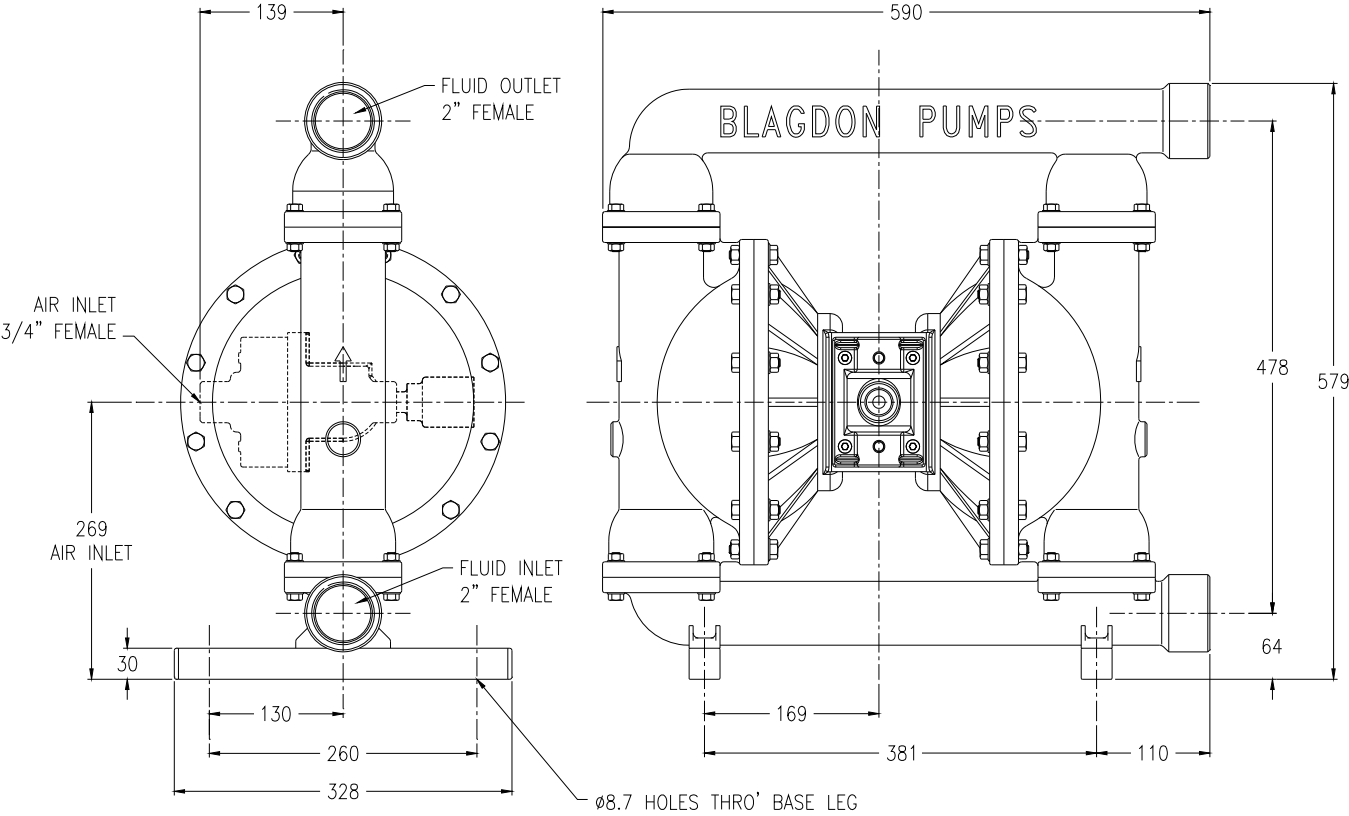

**General Assembly :- B5004 Stainless Steel Pump, all dimensions +/- 2mm**

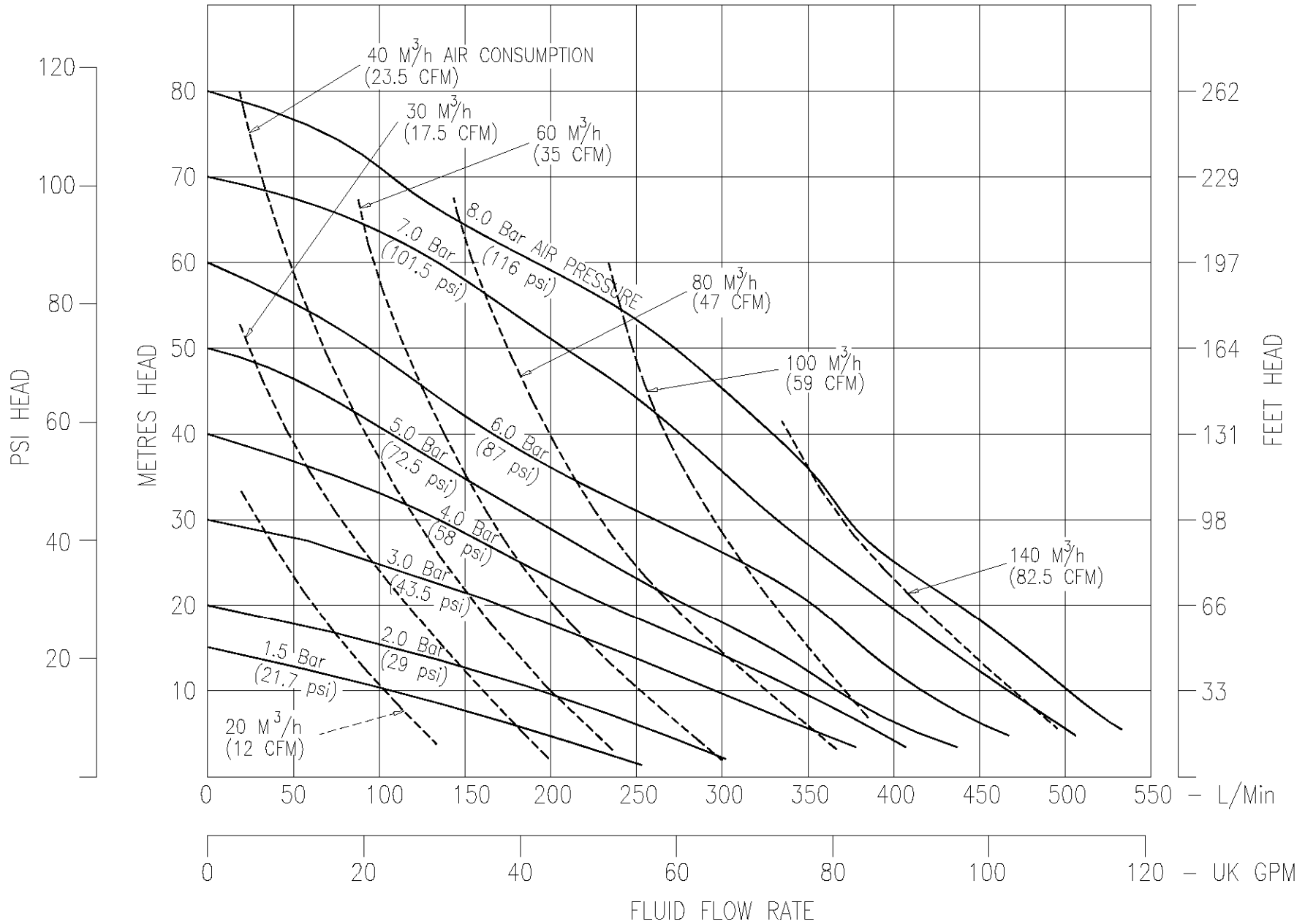

Performance Curve

B50 Metallic Pump Performance Curve, Performance based on water at ambient temperature

## Trouble Shooting Guide & Technical Data

### TROUBLE SHOOTING GUIDE

**NOTE :- Check all solutions before dismantling the pump.**

PROBLEM	CAUSE	SOLUTION
Pump will not start	Air valve assembly malfunction/Seizure  Obstructed fluid line. Obstructed diaphragm chamber. Diaphragm failure causing fluid & excessive air to be expelled through the exhaust. Diaphragm seal failure. Air valve system malfunction. Air connected to exhaust.	Check carrier for freedom of movement. - Clean, oil & replace. Clean line or increase line size. Remove obstruction. Replace diaphragm.  Replace shaft seals. Check all seals in valve chest assembly. Re-connect to air inlet.
Erratic flow	Diaphragm failure on one side. Valve ball not seating. Suction leakage. Diaphragm failure causing fluid & excessive air to be expelled through the exhaust. Diaphragm seal failure. Air valve system malfunction.	Replace diaphragm. Check and remove obstruction. Check and correct. Replace diaphragm.  Replace shaft seals. Check all seals in valve chest assembly.
Pump strokes but will not discharge	Excessive suction lift. Suction line leakage. Valve ball not seating correctly or damaged. Suction line or strainer clogged. Diaphragm failure.	Shorten suction line. Check and correct. Check and remove obstruction / replace. Clear. Replace diaphragm.
Fluid discharged from air exhaust	Diaphragm Failure. Loose frontplate.	Replace diaphragm. Re-Torque to manual specifications.
Intermittent stroke rate	Over lubrication   Diaphragm shaft seal failure. Air valve system malfunction. Valve ball not seating / partially obstructed.	Shut-down pump. Remove air connection into pump & introduce a small quantity of degreasing agent into air valve and replace line. Run pump until clear. Replace seals. Check all seals in valve chest assembly. Clear obstruction.

### TECHNICAL DATA

TECHNICAL DATA				
FLUID CONNECTIONS	CAPACITY	MAX SOLIDS	MAX DISCHARGE HEAD	DISPLACEMENT PER STROKE
2" BSP (F) 2" NPT (F)	0 - 500 Litres/Minute (0 - 110 Gallons/Minute)	6 MM (1/4")	88 Meters (289 ft)	1.9 Litres (0.42 UK Gallons)
MAX. WORKING PRESSURE	AIR INLET	TEMPERATURE LIMITS		PUMP WEIGHTS :-
8.6 Bar (125 psi)	3/4" BSP (F) 3/4" NPT (F)	Determined by Elastomers (See page 3)		AA :- 35 Kg    CC :- 70 Kg CA :- 50 Kg    SA :- 60 Kg SC :- 78 Kg    SS :- 92 Kg

For overall dimensions see page 4

# PRINCIPLE OF PUMP OPERATION

This ball valve type diaphragm pump is powered by compressed air and is a 1:1 ratio design. The inner side of one diaphragm chamber is alternately pressurised while simultaneously exhausting the other inner chamber. This causes the diaphragms, which are connected by a common shaft secured by plates to the centres of the diaphragms, to move in a reciprocating action. (As one diaphragm performs a discharge stroke the other diaphragm is pulled to perform the suction stroke in the opposite chamber.) Air pressure is applied over the entire inner surface of the diaphragm while liquid is discharged from the opposite side of the diaphragm. The diaphragm operates in a balanced condition during the discharge stroke which allows the pump to be operated at discharge heads of over 200 feet (61 meters) of water.

For maximum diaphragm life, keep the pump as close to the liquid being pumped as possible. Positive suction head in excess of 10 feet of liquid (3.048 meters) may require a back pressure regulating device to maximize diaphragm life.

Alternate pressurising and exhausting of the diaphragm chamber is performed by an externally mounted, pilot operated, 2 way type distribution valve. When the spool shifts to one end of the valve block body, inlet pressure is applied to one chamber and the other diaphragm chamber exhausts. When the spool shifts to the opposite end of the valve body, the pressure to the chambers is reversed. This alternating movement of the spool inside the valve body is

controlled by a pilot air pressure signal held against the diaphragm shaft, between seals in the diaphragm shaft bushes. This signal is released, triggering the movement of the spool, when pilot holes in the diaphragm shaft align with the held pilot signal, sending the signal to exhaust, which in-turn causes a pressure imbalance around the spool, sending it to the opposite end of the valve body. This simultaneously sends inlet pressure to the opposite chamber.

The chambers are connected by manifolds with a suction and discharge ball valve for each chamber, maintaining flow in one direction through the pump.

## INSTALLATION

The typical installation shown in FIG. 1 is only a guide to selecting and installing system components. Your installation will depend on the type of fluid being pumped and your application needs. To reduce the risk of serious bodily injury and damage to property, never use fluids in this pump which are not compatible with the wetted components. Contact your local distributor or the manufacturer for system design assistance & compatibility if necessary.

Mount the pump in an upright position. Failure to ensure an upright position may result in loss of or poor priming characteristics. Ensure the pump is securely mounted to avoid movement and possible risk of bodily injury.

**PRESSURE** The pump delivers the same pressure at the discharge outlet as the air pressure applied at the air inlet (unless pump is configured as a 2:1 ratio model).

**NOTE:** *Pressure Regulator (H) should be installed where air supply could exceed 125 psi.*

## SAFETY

Your BLAGDON PUMP is a high performance unit capable of achieving high outputs at high efficiencies. However, as is common with pneumatic equipment, the pump efficiencies is reliant upon the air being clean, dry and filtered. Failure to comply with these requirements may lead to loss of performance and reduced component life and in extreme cases, permanent damage to the pump.

To avoid leaks, ensure that all fluid connections are tight. The use of PTFE thread tape correctly applied should be used to ensure 100% leak proof connections. **Failure to ensure 100% sealability of the suction connection could adversely affect suction performance.**

If you are pumping hazardous fluids, or operating the pump in an enclosed area, it is essential that the exhaust from the pump is piped away to a safe location. When pumping hazardous fluids the above instructions must be adhered to in order to ensure safe operating procedures. (Under certain operating conditions the failure of internal components can lead to the pumped fluid being exhausted via the pump exhaust outlet).

## WARNING

**NEVER place your hands over or near the pump suction inlet. Powerful suction could cause serious bodily injury.**

**FLUSH THE PUMP** This pump was tested with water containing an oil-based rust inhibitor. If this solution could contaminate or react with the fluid you are pumping, flush the pump thoroughly with a solvent/detergent to clean internal components. The solvent/detergent must be compatible with the pump materials of construction. Care should be taken to flush the pump each time it is disassembled for maintenance or repair.

## CAUTION

All BLAGDON PUMPS are built lubricated with grease during assembly and need no further lubrication. If the use of oil cannot be avoided, this will not present any problems. A light No. 2 class lithium grease is recommended. Other grades may cause the Air Logic System to operate intermittently, thereby causing a loss of output and failure to operate. Other seals are available for "clean room" conditions

If the pump accelerates or is running too fast due to a lack of fluid, then stop it immediately by shutting off the air supply. A dry pump will accelerate to a high speed causing wear to elastomers.

If the fluid you are pumping tends to dry up or set when it is not moving, then flush the pump as often as necessary to prevent the fluid from drying in the pump. Drain the pump thoroughly before storing.

If feasible, invert pump to allow any fluid to drain from the non-return valves.

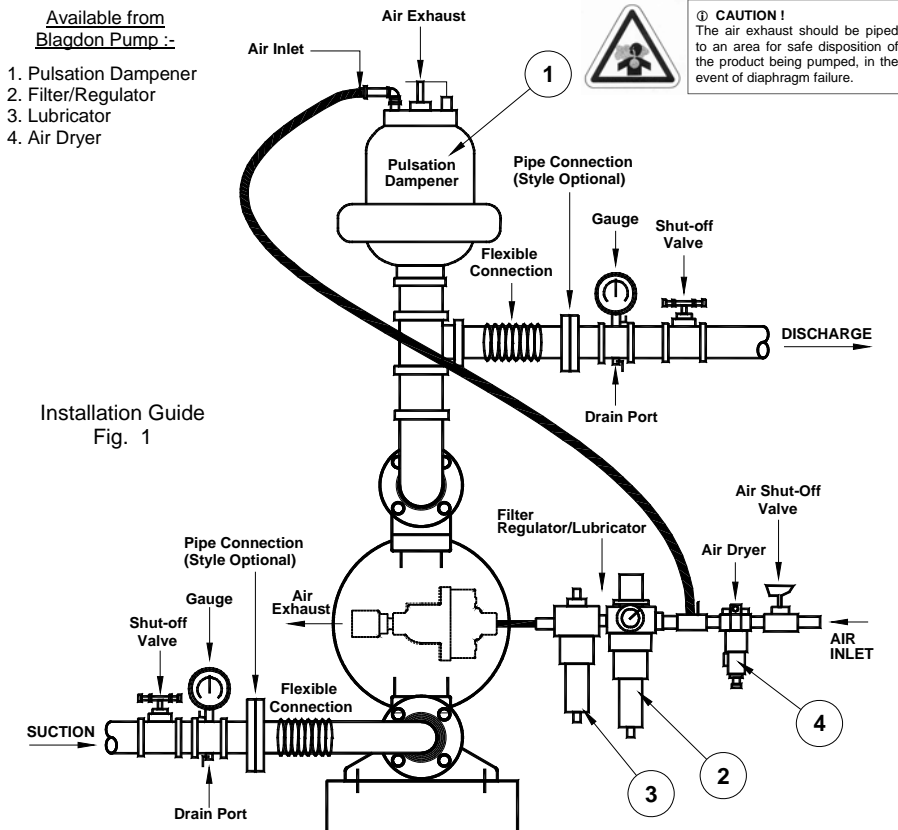

## Important Warnings and Safety Information



### IMPORTANT

Read these safety warnings and instructions in this manual completely, before installation and start-up of the pump. It is the responsibility of the purchaser to retain this manual for reference. This manual must be kept with, and supplied with the pump at all times. Failure to comply with the recommendations stated in this manual will damage the pump, and void factory warranty. These instructions are available if required, in the language or languages of the country or countries in which the equipment is used. Please refer to the manufacturer for details.



### WARNING!

This pump is pressurized internally with air pressure during operation. Always make certain that all bolting is in good condition and that all of the correct bolting is reinstalled during assembly. End-user must ensure correct fitting of Inlet / Outlet connections. Crossed threads or over tightening of connections will result in leaks. Quick action/release connections are not recommended. If their use is unavoidable, the levers must be locked to avoid them being forced apart in a hazardous manner.



### WARNING!

Before maintenance or repair, shut off the compressed air line, bleed the pressure, and disconnect the air line from the pump. The discharge line may be pressurized and must be bled of its pressure. End-user must ensure correct regulation of air supply pressure, as any increase in air pressure results in a similar increase in product pressure if stalled-out.



### WARNING!

Before doing any maintenance on the pump, be certain all pressure is completely vented from the pump, suction, discharge, piping, and all other openings and connections. Be certain the air supply is locked out or made non-operational, so that it cannot be started while work is being done on the pump. Be certain that approved eye protection and protective clothing are worn at all times in the vicinity of the pump. Failure to follow these recommendations may result in serious injury or death.



### WARNING!

Airborne particles and loud noise hazards. Wear ear and eye protection.



### WARNING!

Take action to prevent static sparking. Fire or explosion can result, especially when handling flammable liquids. The pump, piping, valves, containers or other miscellaneous equipment must be grounded. Refer to exhaust safety instructions on page 9.



### WARNING!

When used for toxic or aggressive fluids, the pump should always be flushed clean prior to disassembly. User must ensure chemical compatibility, and any pressure / temperature limits are not exceeded. These instructions include all the information for relevant diaphragm temperature limits. Pump temperature range can also be found on data-plate attached to the pump. If pump is not used for more than 5 days, care must be taken when restarting. If in any doubt, remove pump from line and flush with a suitable cleaner. Solidified deposits within the pump may cause damage to the diaphragms.



### CAUTION!

Before pump operation, inspect all gasketed fasteners for looseness caused by gasket creep. Re-torque loose fasteners to prevent leakage. Follow recommended torques stated in this manual. In cases of excess vibration, Blagdon recommend fitting a Pulsation Dampener to remove effects of pulse actions from pump operation. Flexible connections can be used, but must be kept to a minimum length necessary to avoid sharp flexing or straining movements.



## Exhaust Safety when pumping hazardous liquids



### WARNING!

In the event of diaphragm rupture, pumped material may enter the air end of the pump, and be discharged into the atmosphere. If pumping a product which is hazardous or toxic, the air exhaust must be piped to an appropriate area for safe disposition.

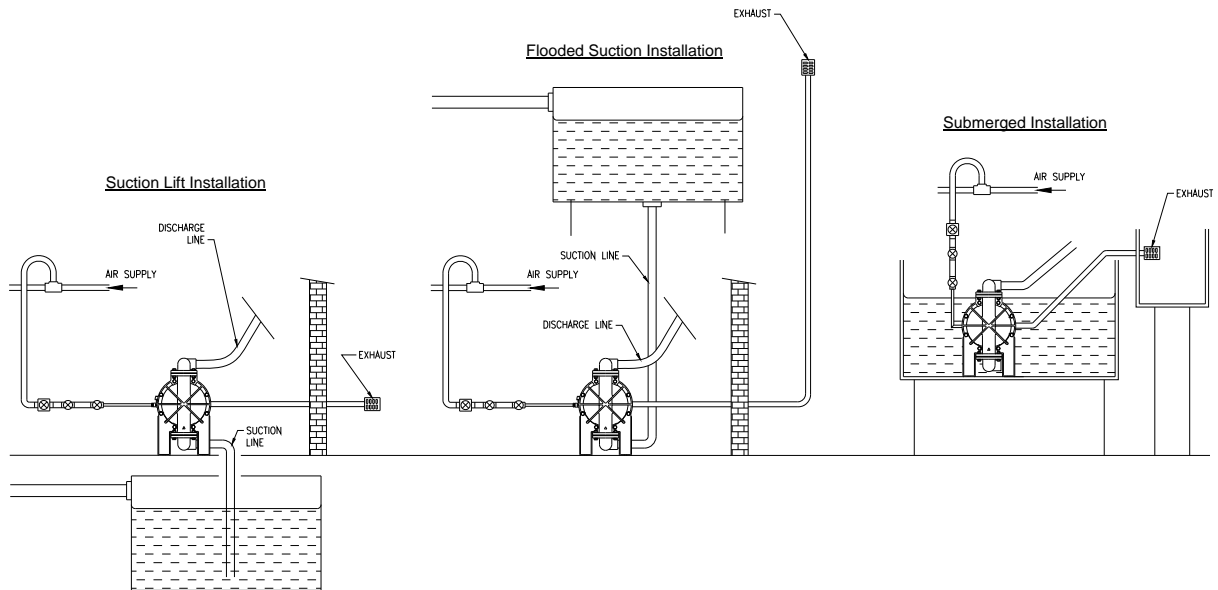

### Exhaust Safety :-

When a diaphragm fails during operation, pumped liquid can enter and contaminate the air side of the pump. If diaphragm failure is not severe, i.e. a small split or hole, then the pump can continue to run, with air being forced into the product being pumped. If however the failure is more serious, then the pump may stop, with fluid or fumes being expelled through the exhaust. Under these conditions it is recommended that the exhaust is piped away to a safe area. In standard suction lift conditions this can simply be done by piping from the exhaust connection to a safe area. Multiple installations can be piped to a common connection, then to a safe area. In flooded suction conditions the exhaust must be taken to a point higher than the fluid level to prevent any siphoning away. In submerged conditions ensure exhaust is piped away above fluid level.

In all conditions ensure exhaust outlet is not expelling across a non-conductive surface. The exhaust must not be placed less than 100mm from any non-conductive surface, as this may generate a propagating brush discharge resulting in a possible ignition source.

## Atex models (see also page 15)

### Grounding the pump :-



### WARNING!

Take action to prevent static sparking. Fire or explosion can result, especially when handling flammable liquids. The pump, piping, valves, containers or other miscellaneous equipment must be grounded.

This unit is supplied with a natural earth ground cable. This cable is 2 meters in length and permanently connected through a stud at one end to the pump centre casting. The other end is free to connect to the nearest available suitable point to provide a natural earth ground. This must be done to reduce the risk of electro-static sparking.

Refer to table on Page 13 for details and relevant Part Numbers.

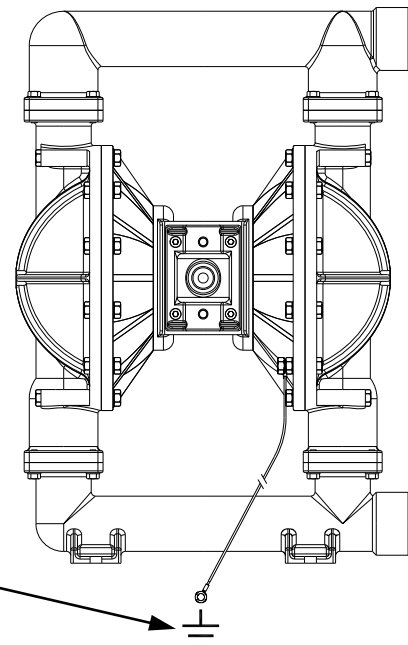



**IMPORTANT !** Read these instructions completely, before installation and start-up. It is the responsibility of the purchaser to retain this manual for reference. Failure to comply with the recommendations stated in this manual will damage the pump, and void factory warranty.

## SERVICE

The following sections give a general overview on how to service all models of BLAGDON Diaphragm Pumps. For details on individual part numbers, quantities, materials, etc., please consult the parts list supplied with the pump.

**NOTE :** *Before commencing any service or maintenance work on the pump, ensure that the air supply has been disconnected or isolated.*

### AIR VALVE OVERHAUL

**PNEUMATIC TYPE** Remove the 4 screws securing the valve block to the valve chest, together with any associated gaskets or seals.

Remove slide valve plate & slide valve from the valve block assembly. Clean all parts thoroughly and inspect for excessive wear, replacing where necessary.

The slide valve and valve plate contact faces should be flat and free from scratches. A light polishing on a flat surface with a fine abrasive paper will remove most scratches.

If excessive wear is suspected in the valve block bore or valve carrier, remove the valve block plugs and withdraw the valve carrier. Check valve block plug o-rings for wear or attack & replace where required.

Clean the valve carrier & valve block bore with white spirits to remove any oil films.

**NOTE :** *The nominal diametrical clearance between the valve carrier and the valve block bore should be 0.05 - 0.09mm. A clearance in excess of this will cause the valve system to run erratically.*

Apply a light grease to the valve block plug O-rings when re-assembling into the valve block bore. Any damage to the O-ring may cause the valve system to malfunction.

Re-assemble the valve block assembly & re-torque in accordance to the settings shown in the parts list.

In the event of a complete air-side

overhaul, the pump should be disassembled down to the centre section assembly as described later in the "Wet-Side Overhaul" section.

With the valve block assembly dismantled, remove the inner covers where appropriate.

A careful note of the position of all related seals and gaskets should be made to facilitate re-assembly.

Remove diaphragm shaft bushes, where appropriate, and check all seals and 'O' rings for wear or damage. If worn, replace immediately.

**NOTE:-** *The integrity of the diaphragm shaft seals is essential for the correct functioning of all pneumatically actuated valve systems.*

Check the diaphragm shaft for excessive wear as this will result in premature seal failure. Replace as required. Lubricate all components and re-assemble as detailed above, in reverse order. Ensure the correct position of all components detailed in all sectional assembly drawings.

### WET-SIDE OVERHAUL

#### **REPLACING BALL VALVES**

Remove discharge manifold from pump assembly together with associated valve balls, seats and 'O' rings.

**NOTE :-** *The orientation of the valve seat relative to the valve ball should be noted as incorrect positioning may result in a performance loss.*

Turn pump through 180° and remove the suction manifold. Clean and inspect the components. Check for any wear or damage and replace as required.

**NOTE :-** *Ball or valve seat wear may result in loss of performance and suction lift.*

Re-assemble the valve balls/seats and ensure manifolds are adequately torqued to the settings shown in the parts list.

#### **REPLACING DIAPHRAGMS**

Remove both suction and discharge manifolds as detailed in the previous

section, removing all ball valves, seats and 'O' rings.

Loosen and remove both outer covers from the pump assembly. The orientation of the covers should be noted so as to facilitate re-assembly.

Holding one of the frontplates in a vice, ('soft jaws' should be fitted), or with an adjustable spanner, loosen and remove the frontplate from the opposite end. Remove the diaphragm, backplate and bumpstop from diaphragm shaft.

Carefully withdraw the diaphragm shaft from the centre section and hold the free end in a vice, holding between the flats machined on the end. Loosen and remove the frontplate and remove the diaphragm together with backplate and bumpstop (where fitted).

**NOTE :-** *Care should be taken with all plastic, coated and hygienic pumps, so that the surface of the frontplate is not damaged.*

Thoroughly clean all parts and check for wear, damage, swelling, cracking, delamination and chemical attack.

Replace components where required.

**NOTE :-** *Rubber diaphragms should be replaced if they are worn to such an extent that the fabric re-enforcing is evident on the surface of the diaphragm.*

For pumps fitted with PTFE diaphragms, a light coating of grease should be applied to the back-up diaphragm prior to re-assembly.

Before re-assembly, it is advisable to check the condition of the diaphragm shaft seal/'O' rings for wear or attack. If either is evident, it is recommended that they be replaced.

Assemble the diaphragms onto the shaft in a reverse sequence to their removal. Care should be taken as to the orientation of the diaphragm relative to the front and back plates. All diaphragms have "AIR SIDE" moulded onto one side. The backplate must be fitted adjacent to the AIR SIDE of the diaphragm.

## PTFE Diaphragms, Torque Settings & Sectional Drawing B5004CC

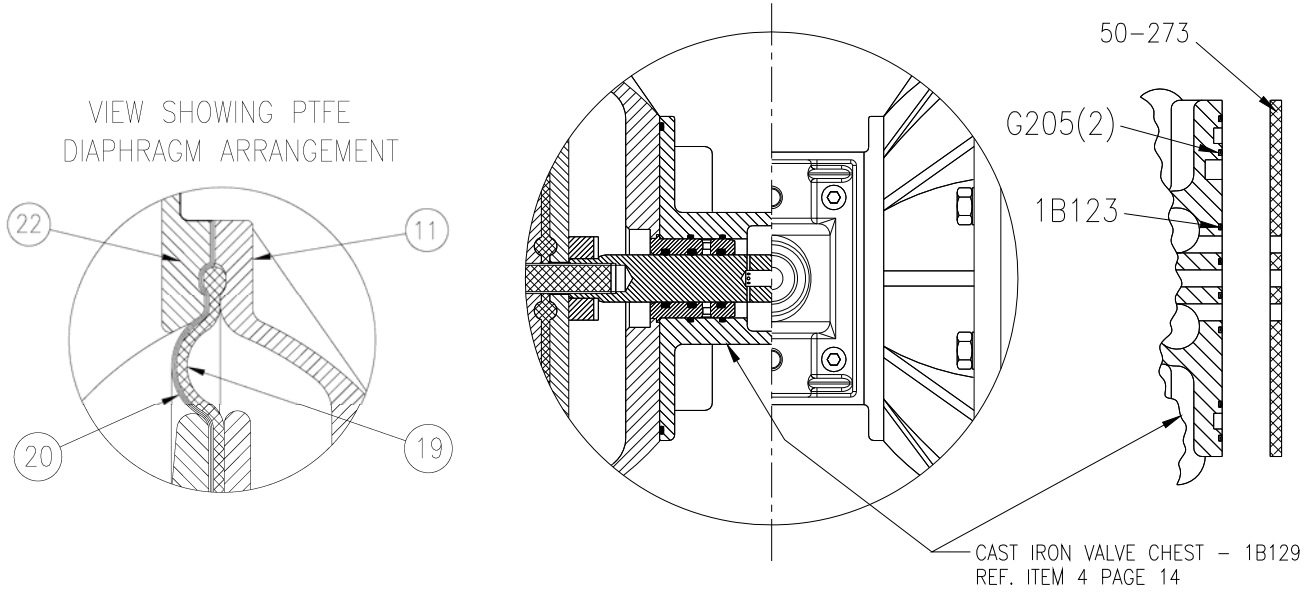

### TORQUE SETTINGS

<b>(A)</b>	FRONTPLATE - 108 Nm (79 lbs/ft)
<b>(B)</b>	OUTER COVERS - 24.3 Nm (17.8 lbs/ft)
<b>(C)</b>	MANIFOLDS - 24.3 Nm (17.8 lbs/ft)
<b>(D)</b>	VALVE BLOCK - (21.6 Nm (16 lbs/ft)

**NOTE!** Pumps fitted with all Cast Iron Valve Chests 1B129 prior to 04 series release, require additional items :-

Transition Plate - 50-273  
 Port Seal - 1B123  
 O-Rings - G205 2 off  
 For remaining Valve Block parts see page 14.

**NOTE !** 04 Series pumps with Cast Iron centre's no longer require the transition plate and additional seals, being built to same specification as Aluminium centre's.

## Elastomer Table

ELASTOMERS COMMON TO ALL MODELS				AA, CA & CC		SA, SC & SS		
DESCRIPTION	VALVE BALL	VALVE BALL - WTD.	DIAPHRAGM	VALVE SEAT	O-RING	VALVE SEAT	O-RING	O-RING
REF. NO	5	5	13	7	9	7	8	6
QTY.	4	4	2	4	4	4	4	4
MATERIAL								
BUNA-N	1B010	1B079	1B004	50-276	G029	50-044	G420	G457
EPDM	1B052	1B080	1B002	50-277	G031	50-046	G418	G459
VITON	1B055	1B088	1B003	-	G119	50-047	G427	G460
NEOPRENE	1B056	1B027	1B001	50-275	G149	50-045	G426	G458
PTFE	1B053	-	SEE 19 & 20	-	G111	50-048	G416	G461
ONE-PIECE PTFE	-	-	50-221	-	-	-	-	-
POLYESTER	-	-	1B029	-	-	-	-	-
DELFIN	1B065	-	-	-	-	-	-	-
POLYURETHANE	-	-	1B048	-	-	-	-	-
SANTOPRENE	-	-	50-233	-	-	-	-	-
STAINLESS STEEL	1B109	-	-	1B051	-	50-072	-	-
ALUMINIUM	-	-	-	1B009	-	-	-	-

For details on ordering Wet-Side kits refer to items marked ♦ in main table and also to the details on page 16.

## Sectional Drawings B5004

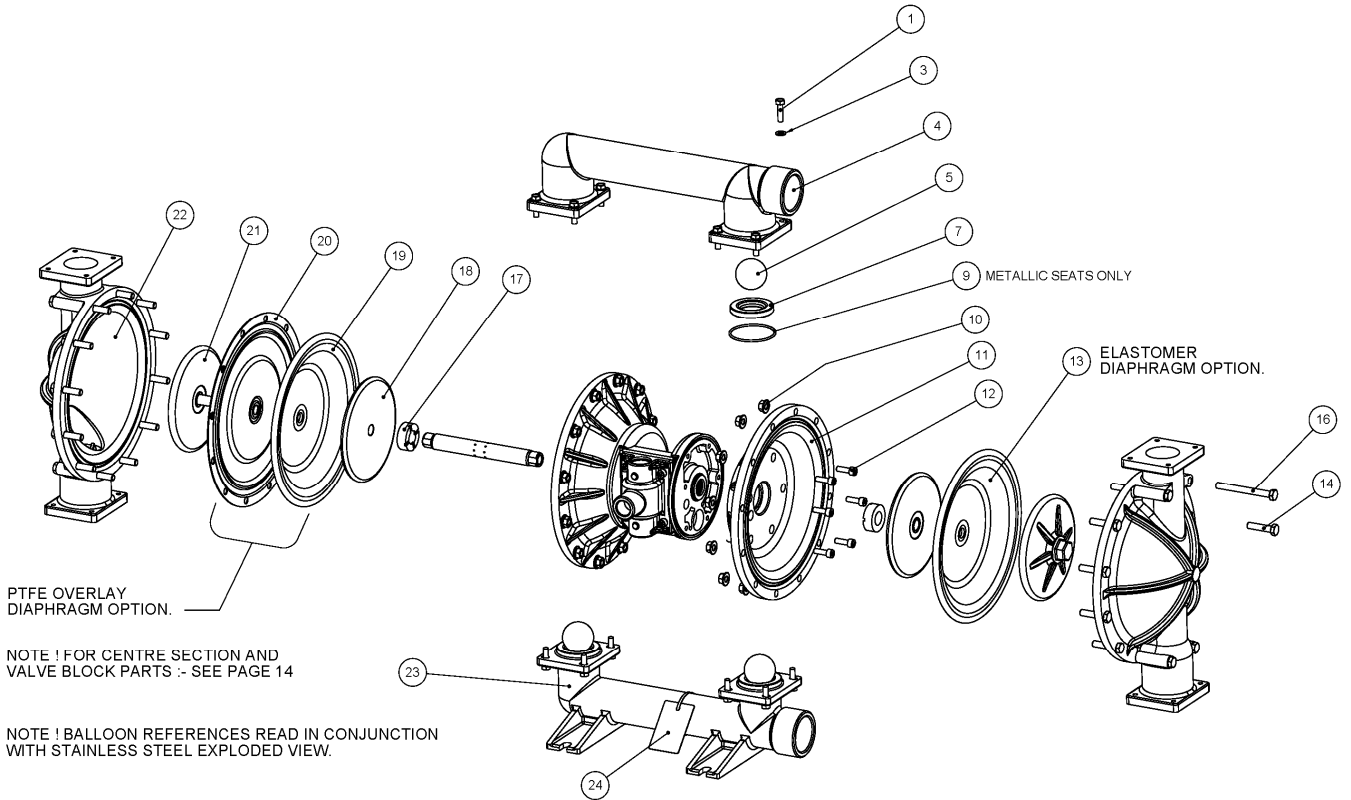

**Sectional General Assembly :- B5004 All Aluminium Pump, refer to page 13 Parts List table for item Ref. Nos.**

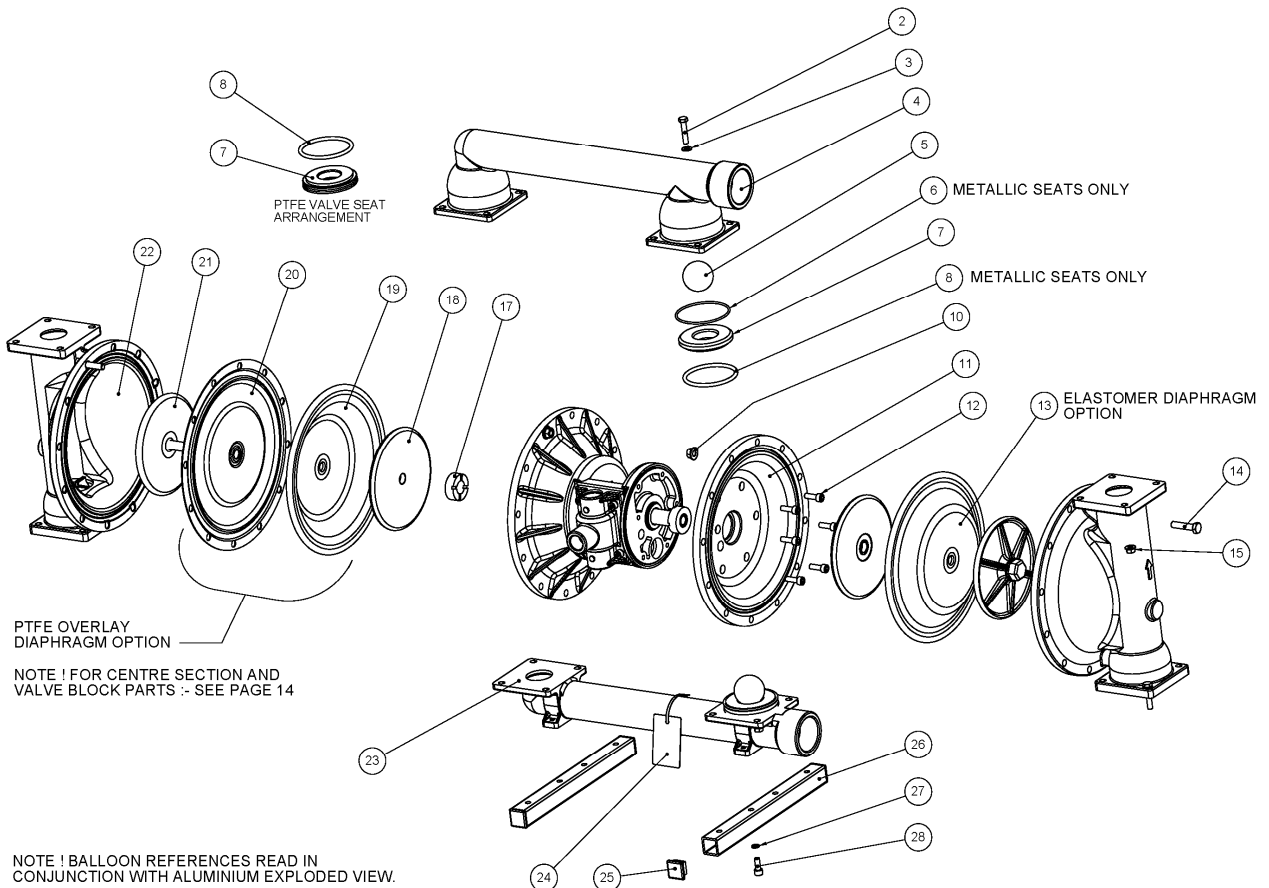

**Sectional General Assembly :- B5004 Stainless Steel / Aluminium Pump, refer to page 13 Parts List table for item Ref. Nos.**

## Wet Side Parts List - (Ref. Nos. are common to all models, pages 12)

REF No.	PART NUMBER				DESCRIPTION	QTY
	ALUMINUM (COMMON)	CAST IRON	STAINLESS STEEL	HIGH TEMPERATURE		
1	A041	-	A042	-	BOLT - HEX. HD. (C) M8 x 30	16
2	A005	-	A040	-	BOLT - HEX. HD. (C) M8 x 35	16
3	C013	-	C044	-	WASHER M8	16
4	50-255 50-274	50-260	50-032 50-130	-	DISCHARGE MANIFOLD - BSP DISCHARGE MANIFOLD - NPT	1 1
5	SEE TABLE	-	1B109	-	VALVE BALL	◆ 4
6	SEE TABLE	-	-	-	O-RING (METALLIC SEATS ONLY)	◆ 4
7	SEE TABLE	-	SEE TABLE	-	VALVE SEAT	◆ 4
8	SEE TABLE	-	-	-	O-RING (METALLIC & PTFE SEATS ONLY)	◆ 4
9	SEE TABLE	-	-	-	O-RING (METALLIC SEATS ONLY)	◆ 4
10	B507	-	B508	-	FLANGED NUT - SERRATED M10	24
11	1B026	1B073	50-303	-	INNER COVER	2
12	D028	-	D310	-	SOCKET CAP SCREW M8 x 25	12
13	SEE TABLE	-	-	-	DIAPHRAGM	◆ 2
14	A151	-	A145	-	BOLT - HEX. HD. (B) M10 x 45	24/16
15	B505	-	B506	-	FLANGED NUT - SERRATED M8	16
16	A496	-	-	-	BOLT - HEX. HD. (B) M10 x 100	8
17	1B015	-	-	1B177	BUMP STOP	2
18	1B021	-	50-055	-	BACKPLATE	2
19	1B054	-	-	1B003	SUPPORT DIAPHRAGM	◆ 2
20	1B039	-	-	-	DIAPHRAGM - PTFE OVERLAY	◆ 2
21	SA10042	SA10044	SA10044	-	FRONTPLATE ASSEMBLY (A)	2
22	50-253	50-258	50-052	-	OUTER COVER	2
23	50-254 50-265	50-259	50-033 50-129	-	SUCTION MANIFOLD - BSP SUCTION MANIFOLD - NPT	1 1
24	SP475	-	-	-	NAMEPLATE	1
25	-	-	1B034	-	BASE LEG CAP	4
26	-	-	50-074	-	BASE LEG	2
27	C165	-	C173	-	WASHER - SPRING M8	4
28	D490	-	D372	-	SOCKET CAP SCREW M8 x 16	4
<b>Atex models only :-</b>						
31	1A060	-	-	-	NAMEPLATE - SERIAL NO./MODEL NO. (REPLACES ITEM 27)	1
32	SA10528	-	-	-	GROUNDING LEAD ASSEMBLY	1
33	SP467	-	-	-	ATEX NAMEPLATE	1
34	SP474	-	-	-	TIE-LOK TIE	1

◆ - **Wet Side Kits** - These items are available in a recommended spares kit. Please refer to matrix on page 16 for details on part numbers for ordering purposes or refer to your local stockist / distributor for further details.

**Note! Wet Side Kits only include valve seats if the original parts were rubber :- i.e. Buna-N, Neoprene etc.**

(B) Indicates Torque setting required. See page 11 for details.

### HIGH TEMPERATURE INSTALLATIONS

In situations where the temperature of the fluid to be pumped is likely to exceed 100°C, a high temperature pump code must be specified. This is signified using an 'X' in the last part of the pump code as shown.

"XTS" in place of "TTS". Reference Pump Code matrix on page 3

This indicates the following specification amendments :-

Diaphragm shaft seals will be changed from Polurethane to Viton. Back-up diaphragms and any bumpstops will be changed to Viton. In extreme cases only, any gaskets could be changed to a higher temperature spec., and the diaphragm shaft bushes could be changed from plastic to metal.

Refer to main table above and on page 14 for quantities / pump.

## Air Side Parts List - (Ref. Nos. are common to all models)

### Centre Section / Valve Block components :-

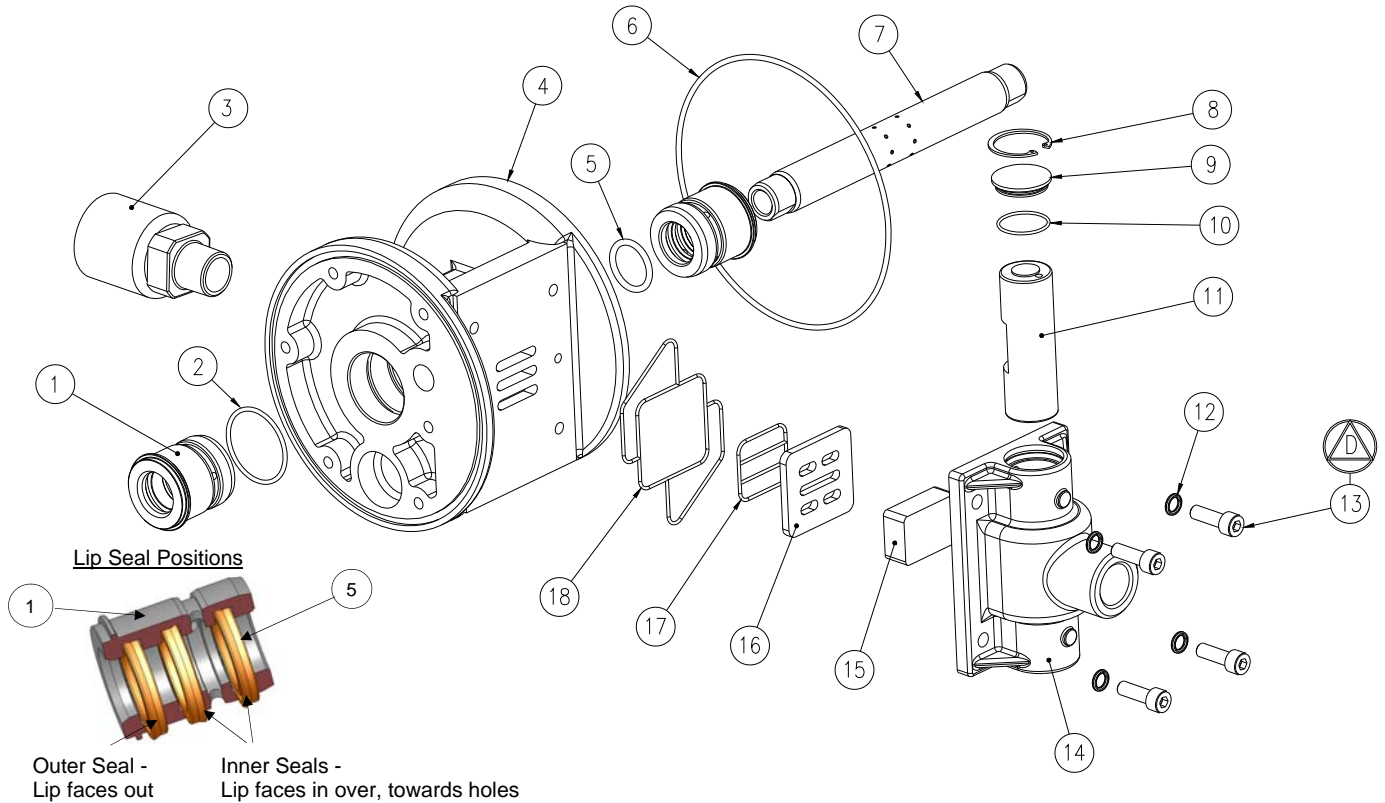

REF No.	PART NUMBER					DESCRIPTION	QTY
	ALUMINIUM (COMMON)	CAST IRON	STAINLESS STEEL	HIGH TEMPERATURE	LUBE FREE		
1	50-315	-	-	50-281	1B020	DIAPHRAGM SHAFT BUSH	2
2	G091	-	-	G324	-	O-RING	4
3	1B114	-	-	-	-	SILENCER	1
4	50-257	1B129	50-304	-	-	VALVE CHEST	1
5	50-207	-	-	G323	50-227	SHAFT SEAL	6
6	G112	-	-	-	-	O-RING	2
7	SA10041	-	-	-	-	DIAPHRAGM SHAFT	1
8	H125	-	-	-	-	CIRCLIP	2
9	1C021	-	-	-	-	VALVE BLOCK PLUG	2
10	G130	-	-	G329	-	O-RING	2
11	1B124	-	-	-	-	VALVE CARRIER	1
12	C165	-	C173	-	-	SPRING WASHER M8	4
13	D028	-	D310	-	-	SOCKET CAP SCREW (D) M8 x 25	4
14	-	-	50-246 50-247	-	-	VALVE BLOCK - BSP VALVE BLOCK - NPT	1 1
15	50-251	-	-	-	-	SLIDE VALVE	1
16	50-248	-	-	-	-	SLIDE VALVE PLATE	1
17	1B123	-	-	1B176	-	PORT SEAL	1
18	50-261	-	-	50-282	-	VALVE BLOCK SEAL	1

### Spares Kits

□ - **Air Side Kits** - See page 16 for all available kits

❖ - **Valve Block Sub-Assemblies** - See page 16 for all available kits

(B) Indicates torque setting required. See page 11 for details.

## Atex Certified Models

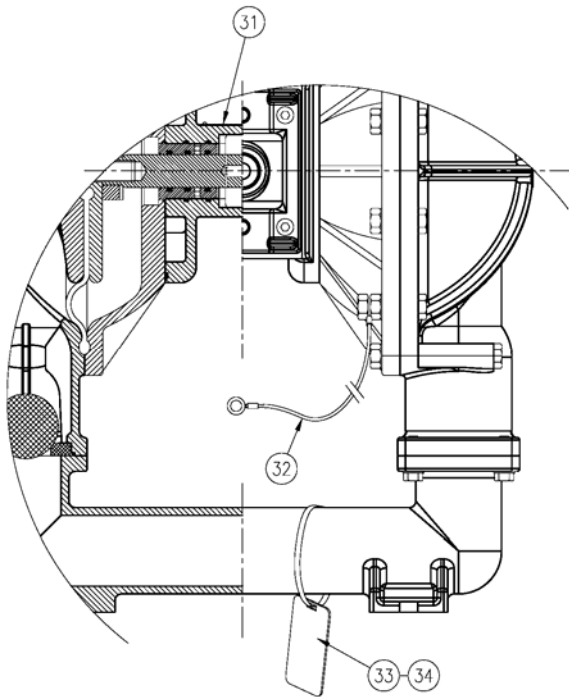

Refer to Parts List on page 13 for parts additional for Atex Certified models. All models are certified as shown on page 1 of this manual. Maximum temperature of fluid to be handled must be specified at time of order. Pump must be marked with this information. For grounding details refer to page 9.



### WARNING!

Take action to prevent static sparking. Fire or explosion can result, especially when handling flammable liquids. The pump, piping, valves, containers or other miscellaneous equipment must be grounded.



### WARNING!

When used for toxic or aggressive fluids, the pump should always be flushed clean prior to disassembly. User must ensure chemical compatibility, and any pressure / temperature limits are not exceeded. These instructions include all the information for relevant diaphragm temperature limits. Pump temperature range can also be found on data-plate attached to the pump. If pump is not used for more than 5 days, care must be taken when restarting. In any doubt, remove pump from line and flush with a suitable cleaner. Solidified deposits within the pump may cause damage to the diaphragms.



### CAUTION!

Before pump operation, inspect all gasketed fasteners for looseness caused by gasket creep. Re-torque loose fasteners to prevent leakage. Follow recommended torques stated in this manual. In cases of excess vibration, Blagdon recommend fitting a Pulsation Dampener to remove effects of pulse actions from pump operation. Flexible connections can be used, but must be kept to a minimum length necessary to avoid sharp flexing or straining movements.

## Pumps fitted with Suction / Discharge Pipe Flanges & Base Pads

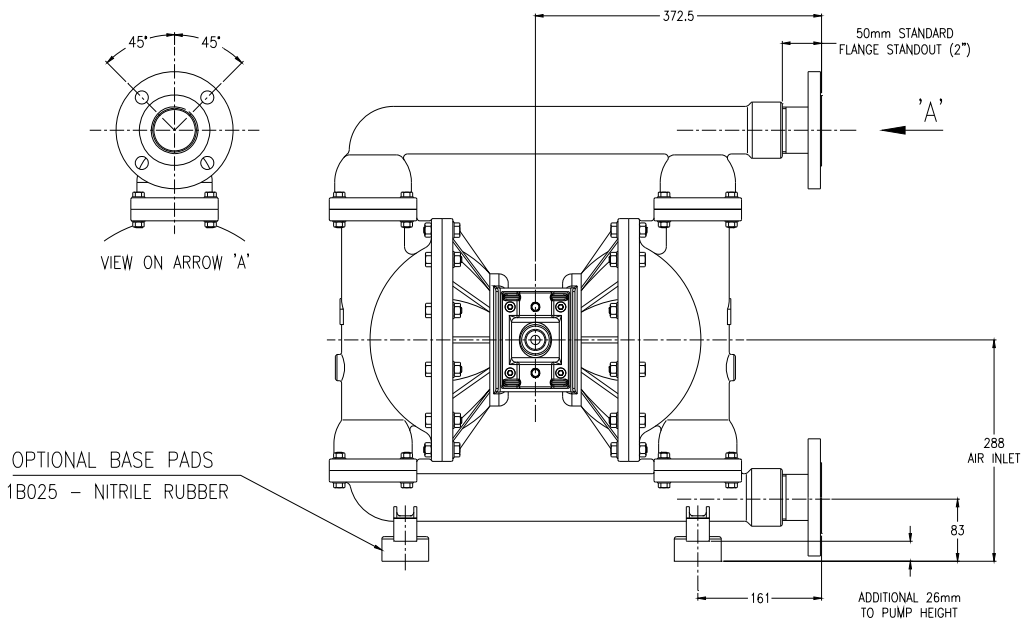

Pumps can be supplied complete with pipe flanges to a set standoff from the end faces of the inlet / outlet manifolds. This distance is specified above, with additional data, i.e. flange bolt hole positions and any changes in overall pump dimensions. Flanges are normally supplied as ANSI 150 matched to the normal inlet / outlet size of the pump. Base pads would normally be supplied loose in order to mount pump level.

i.e. a 2" BSP model would be fitted with 2" ANSI 150 flanges. Other flanges can be ordered i.e. ANSI 300, PN16. Refer to Supplier / Manufacturer for details regarding Part Nos., available types, etc.

## Wet Side Kit Structure

### Diaphragm Pump Wet-Side Kits - Part Number Structure

The format of the Wet-Side Kit part number is broken down as shown below. The number always starts with 'WSK' followed by the model number, diaphragm letter, ball valve letter and pump material. If rubber seats are used, an 'R' is added to the end. A 'W' is added following the pump body material letter if pump is fitted with weighted balls. These are not available for sizes below 1". An 'S' is used in place of the 'M' in cases where the Stainless Steel model uses different seals than the Aluminium model. This applies to later 06 pumps, and all B15 and B50 pumps.

NOTE! This part number system does not apply to pumps designated :- X4001, X5001 or X7501. Please consult the pump Service & Operating Manuals for Wet-Side Kit numbers for these models. If in doubt please consult Sales at Blagdon Pump.

**TYPICAL CODE =      WSK 50 N N M W 3**

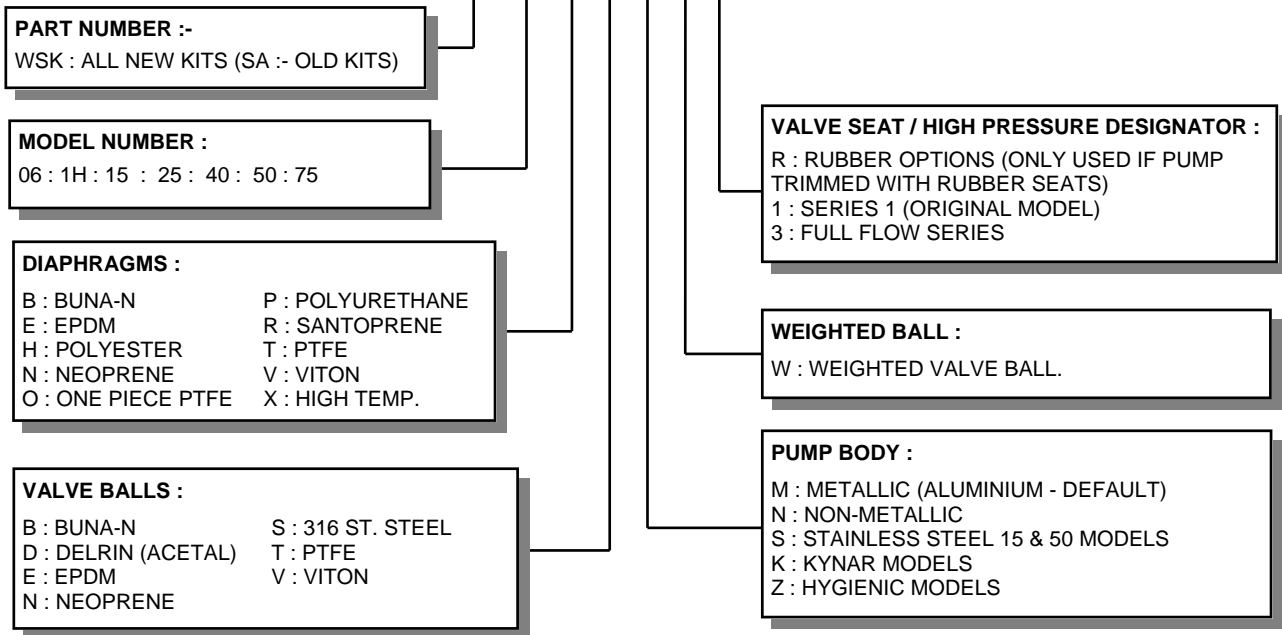

## Spares Kits

The following details refer to the main recommended spares kits available for your Blagdon Pump. Not all combinations and trim options are listed here. Please refer to your local stockist / distributor if you require further details or availability of other kits.

- - **Air Side Kits** - ASK5004 - Standard Air side kit.  
ASK5004-LF - Lube Free Air Side Kit.  
SA10501 - Pumps c/w Cast Iron Valve Chests.
- ❖ - **Valve Block Sub-Assemblies** -  
SA10491 - BSP  
SA10492 - NPT  
SA10495 - Cast Iron Valve Chests. - BSP
- ◆ - **Wet Side Kits** -      WSK5004BBM              WSK5004BBMR              WSK5004ETM              WSK5004EEM              WSK5002EEWR  
                                 WSK5004NNM              WSK5004NNMR              WSK5004NNWR              WSK5004PBM              WSK5002RTM  
                                 WSK5004TTM              WSK5004TSS              WSK5004VSM              WSK5004VVM              WSK5002RTM
- - **Filter/Regulator/Lubricator - FRL**              XFRL50 - (Standard unit for all models.)
- - **Base Pads**                      1B025 - Available for all models on request (4 per pump)



## Service / Maintenance Log

Date	Details	Completed

### Notes

---

---

---

---

---

---

---

---

---

---

---

---

---

---

---

---

---

---

---

---

---

---

---



**RECYCLING**

Many components of BLAGDON air operated double diaphragm pumps are made of recyclable materials. We encourage pump users to recycle worn out parts and pumps whenever possible, after any hazardous pumped fluids are thoroughly flushed.

# Declaration of Conformity

DECLARATION DE CONFORMITE • DECLARACION DE CONFORMIDAD • ERKLÄRUNG BEZÜGLICH EINHALTUNG DER VORSCHRIFTEN •  
DICHIARAZIONE DI CONFORMITÀ • CONFORMITEITSVERKLARING • DEKLARATION OM ÖVERENSSTÄMMELSE •  
EF-OVERENSSTÄMMELSESERKLÄRING • VAATIMUSTENMUKAISUUSVAKUUTUS • SAMSVARSERKLÄRING • DECLARAÇÃO DE CONFORMIDADE •  
Δήλωση Συμμόρφωσης

## MANUFACTURED BY:

FABRIQUE PAR:  
FABRICADA POR:  
HERGESTELLT VON:  
FABBRICATO DA:  
VERVAARDIGD DOOR:  
TILLVERKAD AV:  
FABRIKANT:  
VALMISTAJA:  
PRODUSENT:  
FABRICANTE:  
Κατασκευαστής:

## BLAGDON PUMP

A Unit of IDEX Corporation

Lambert Road, Armstrong,  
Washington, Tyne & Wear.  
NE37 1QP, England.  
Tel. +44 (0) 191 4177475  
Fax. +44 (0) 191 4175435



## PUMP

### MODEL, TYPE

MODELE, TYPE  
MODELO, TIPO  
MODELL, TYPE:  
MODELLO, TIPO  
MALLI, TYYPI:  
ΜΟΝΤΕΛΟ, ΤΥΠΟΣ:

## SERIAL NO.:

NO. SERIE:  
NO. DE SERIE:  
SERIEN-NR.:  
NUMERI DI SERIE  
SERIENUMMERS:  
TILLVERKNINGS NUMMER:  
SERIENR.:  
SARJA NO.:  
SERIE NR.:  
ΑΡ. ΣΕΙΡΑΣ:

## This product complies with the following European Community Directives:

Ce produit est conforme aux directives de la Communauté européenne suivantes:

Este producto cumple con las siguientes Directrices de la Comunidad Europea:

Dieses produkt erfüllt die folgenden Vorschriften der Europäischen Gemeinschaft:

Questo prodotto è conforme alle seguenti direttive CEE:

Dir produkt voldoet aan de volgende EG-richtlijnen:

Denna produkt överensstämmer med följande EU direktiv:

Blagdon Pump, erklærer herved som fabrikant, at ovennævnte produkt er  
i overensstemmelse med bestemmelserne i Direktive:

Tämä tuote täyttää seuraavien EC Direktiivien vaatimukset:

Dette produkt oppfyller kravene til følgende EC Direktiver:

Este produto está de acordo com as seguintes Directivas comunitárias:

Το παρόν προϊόν πληροί τις εξής οδηγίες της ΕΕ:

**98 / 37 / EC**

## This product has used the following harmonized standards to verify conformance:

Ce matériel est fabriqué selon les normes harmonisées suivantes, afin d' en garantir la conformité:

Este producto cumple con las siguientes directrices de la comunidad europea:

Dieses produkt ist nach folgenden harmonisierten standards gefertigt worden, die übereinstimmung wird bestätigt:

Questo prodotto ha utilizzato i seguenti standards per verificare la conformità:

De volgende geharmoniseerde normen werden gehanteerd om de conformiteit van dit produkt te garanderen:

För denna produkt har följande harmoniserande standarder använts för att bekräfta överensstämmelse:

Harmoniserede standarder, der er benyttet:

Tässä tuotteessa on sovellettu seuraavia yhdenmukaistettuja standardeja:

Dette produkt er produsert i overensstemmelse med følgende harmoniserte standarder:

Este produto utilizou os seguintes padrões harmonizados para verificar conformidade:

Το παρόν προϊόν χρησιμοποιεί τα ακόλουθα μέτρα και σταθμά εναρμονισμού για την επιβεβαίωση της συμμόρφωσης:

**EN 809**

## AUTHORIZED / APPROVED BY:

Approuvé par:  
Aprobado por:  
Genehmigt von:  
approvato da:  
Goedgekeurd door:

Underskrift:  
Valtuutettuna:  
Bemyndiget av:  
Autorizado Por:  
Εγκρίθηκε από:

Jeff Sill,  
General Manager

DATE: December 15, 2000

FECHA:  
DATUM:  
DATA:  
DATO:  
PÄIVÄYS:  
Ημερομηνία:



HG-CF-223 (REV 4)